

# BALANCERS

## Types

### BALANCERS

Type	Brand	Capacity kg	Cable length m	Weight kg
RRI-9001/1	RRI	0,5 - 1,5	2	0,5
RRI-9003/1	RRI	1 - 3	2	0,7
RRI-9005/1	RRI	2,5 - 5	2	0,9
EK-0	RRI	0,5 - 1,5	1	0,5
TW-3	RRI	1 - 3	1,3	1,4
TW-5	RRI	2,5 - 5	1,3	1,5
TW-9	RRI	4,5 - 9	1,3	3,4
TW-15	RRI	9 - 15	1,3	3,8
TW-22	RRI	15 - 22	1,5	7,2
TW-30	RRI	22 - 30	1,5	7,6
TW-40	RRI	30 - 40	1,5	9,8
TW-50	RRI	40 - 50	1,5	10,4
TW-60	RRI	50 - 60	1,5	11,6
TW-70	RRI	60 - 70	1,5	11,8
ETP-14	RRI	120 - 140	1,2	24,1
ETP-15	RRI	140 - 170	1,2	28,7
ETP-16	RRI	170 - 200	1,2	29,7



RRI-9001/1

RRI-9003/1

RRI-9005/1



EK-0

EK-00



TW3

TW-5



TW9

TW-70

### SPRINGBALANCERS: HOSEREEL WITH INTEGRATED CABLE

Type	Brand	Capacity kg	Cable length m	Weight kg	Hose diameter mm	Air cons. l/min	Inlet thread
HTB-0	RRI	0,5 - 1,5	1,3	1,58	6,5	700	PT 1/4"
HTB-1	RRI	1,5 - 3	1,3	1,66	6,5	700	PT 1/4"
HTB-2	RRI	3 - 5	1,3	1,73	6,5	700	PT 1/4"



HTB-0

HTB-1

HTB-2

### SPRINGBALANCERS: LONG STROKE

Type	Brand	Capacity kg	Cable length m	Weight kg
ELF-3	RRI	1,5 - 3	2,5	4,1
ELF-5	RRI	3 - 5	2,5	4,2
ELF-9	RRI	5 - 9	2,5	4,7
ELF-15	RRI	9 - 15	2,5	10
ELF-22	RRI	15 - 22	2,5	10,2
ELF-30	RRI	22 - 30	2,5	11
ELF-40	RRI	30 - 40	2,5	14
ELF-50	RRI	40 - 50	2,5	14,5
ELF-60	RRI	50 - 60	2,5	17
ELF-70	RRI	60 - 70	2,5	18



ELF-3 - ELF-70

#### EXTRA SAFETY

The models ELF and TW from TW-9 upwards have a safety mechanism which activates in case of spring breakage.

#### DIMENSIONS

You can find the dimensions of our spring balances on our website.

# BALANCERS

## Dimensions

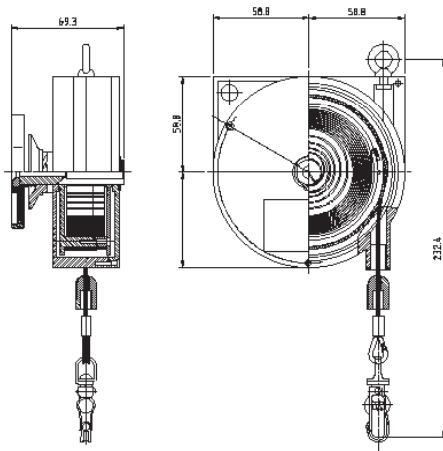

RRI-9001/1

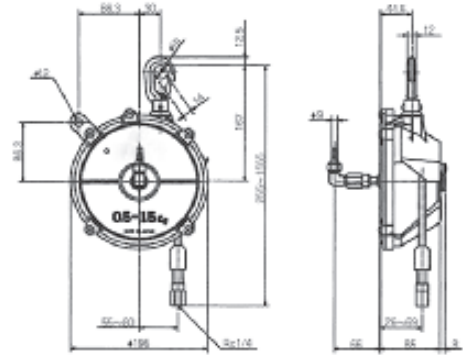

HTB-0 HTB-1 HTB-2

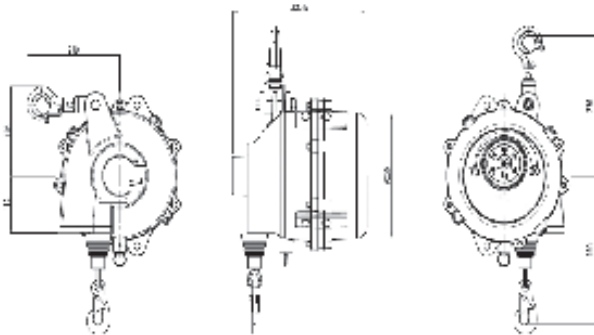

TW-3 t/m 70

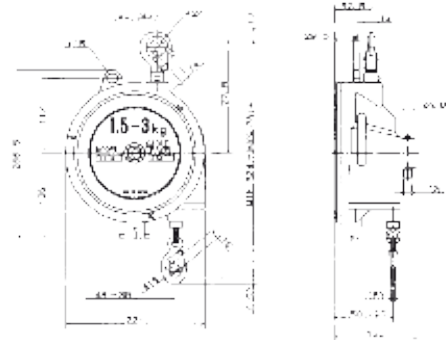

ELF-3 ELF-5 ELF-9

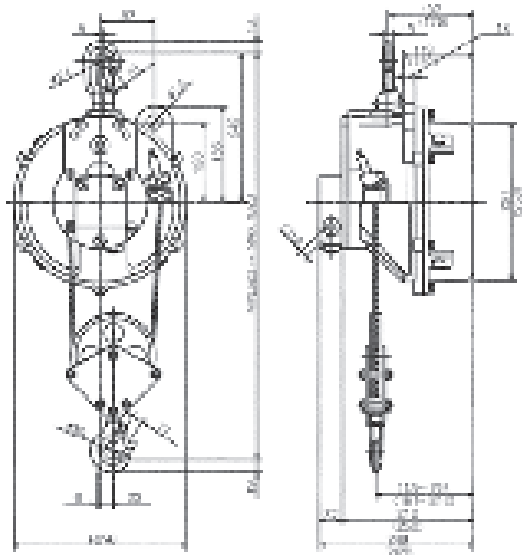

ETP-14\_15\_16

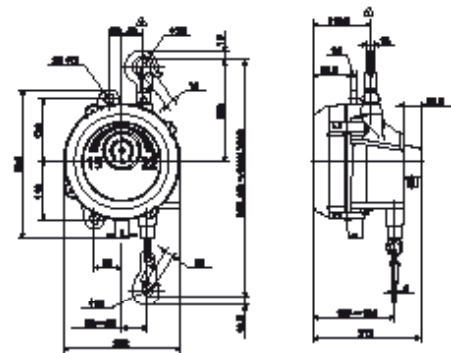

ELF-15 ELF-22 ELF-30

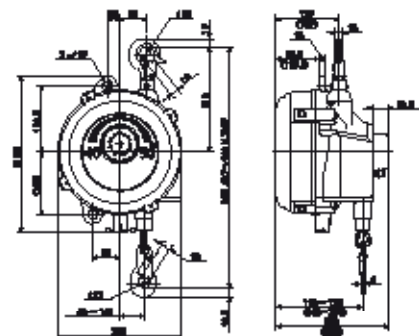

ELF-40 ELF-50 ELF-60 ELF-70